

# **A2 PHYSICS PAST PAPER QUESTIONS**

## **UNIT 4 – Waves and the Universe**

### **1. Circular Motion:**

Question 1 to 6 (Circular Motion)

Pages 1 to 30

### **2. Waves and Superposition**

Question 1 to 11 (Waves)

Pages 31 to 41

Question 12 to 24 (Superposition)

Pages 41 to 57

### **3. Quantum Phenomena and Universe**

Question 1 to 11 (Quantum Phenomena)

Pages 58 to 67

Question 12 to 16 (Expanding Universe)

Pages 68 to 73

1. Define simple harmonic motion.

.....  
.....

(2)

The curve labelled A shows how the displacement of a body executing simple harmonic motion varies with time.

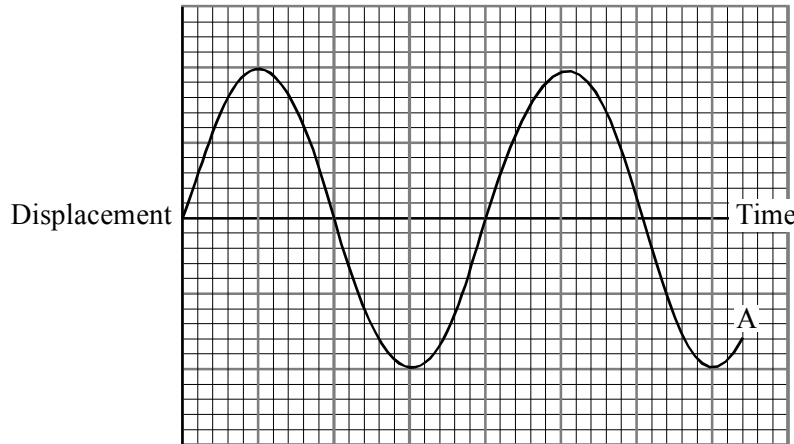

Add the following to the graph:

- (i) A curve labelled B showing how the acceleration of the same body varies with time over the same time period.
- (ii) A curve labelled C showing how the velocity of the same body varies with time over the same time period.

(4)

Which pair of curves illustrates the definition of simple harmonic motion?

.....

Explain your answer.

.....  
.....  
.....  
.....

(3)

(Total 9 marks)

2. The diagram below shows a mass of 0.51 kg suspended at the lower end of a spring. The graph shows how the tension,  $F$ , in the spring varies with the extension,  $\Delta x$ , of the spring.

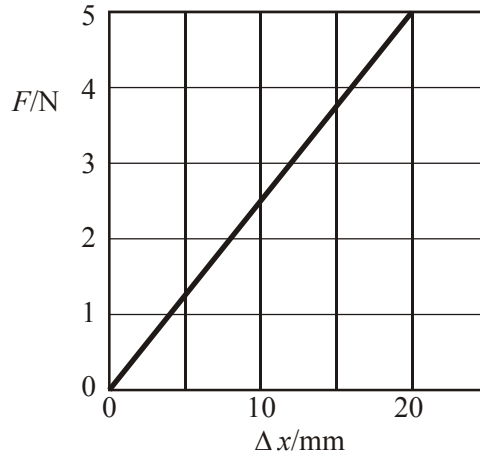
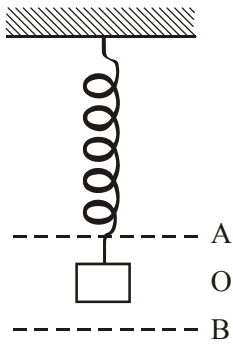

Use the graph to find a value for the spring constant  $k$ .

.....  
 .....

$k =$  .....

(2)

The mass, originally at point O, is set into small vertical oscillations between the points A and B. Choose A, B or O to complete the following sentences.

The speed of the mass is a maximum when the mass is at .....

The velocity and acceleration are both in the same direction when the mass is moving from ..... to..... .

(2)

Calculate the period of oscillation  $T$  of the mass.

.....  
 .....

Period of oscillation  $T =$  .....

(2)

What energy transformations take place while the mass moves from B to O?

.....  
.....  
.....

(2)  
**(Total 8 marks)**

3. A simple pendulum has a period of 2.0 s and oscillates with an amplitude of 10 cm. What is the frequency of the oscillations?

.....

Frequency = .....

(1)

At what point of the swing is the speed of the pendulum bob a maximum?

.....

Calculate this maximum speed.

.....  
.....  
.....

Maximum speed = .....

(3)

At what points of the swing is the acceleration of the pendulum bob a maximum?

.....

Calculate this acceleration.

.....  
.....  
.....

Maximum acceleration = .....

(3)  
**(Total 7 marks)**

4. A satellite orbits the Earth once every 120 minutes. Calculate the satellite's angular speed.

.....  
.....  
.....  
.....

angular speed = .....

(2)

Draw a free-body force diagram for the satellite.

(1)

The satellite is in a state of free fall. What is meant by the term *free fall*? How can the height of the satellite stay constant if the satellite is in free fall?

.....  
.....  
.....  
.....  
.....

(3)

(Total 6 marks)

5. A student was studying the motion of a simple pendulum the time period of which was given by  $T = 2\pi (l/g)^{1/2}$ .

He measured  $T$  for values of  $l$  given by

$$l/m = 0.10, 0.40, 0.70, 0.70, 1.00$$

and plotted a graph of  $T$  against  $\sqrt{l}$  in order to deduce a value for  $g$ , the free-fall acceleration. Explain why these values for  $l$  are poorly chosen.

.....  
.....  
.....

(1)

How would the student obtain a value of  $g$  from the gradient of the graph?

.....  
.....  
.....  
.....

(2)

The graph below shows three cycles of oscillation for an undamped pendulum of length 1.00 m.

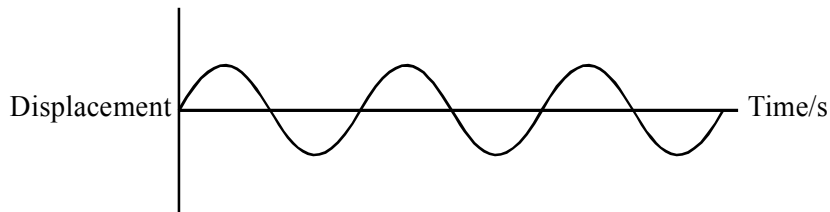

Add magnitudes to the time axis and on the same axes show three cycles for the same pendulum when its motion is lightly air damped.

(4)

(Total 7 marks)

6. A body oscillates with simple harmonic motion. On the axes below sketch a graph to show how the acceleration of the body varies with its displacement.

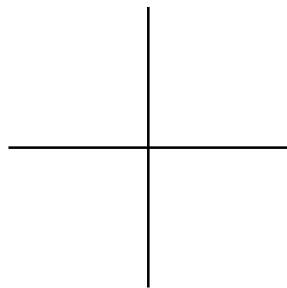

(2)

How could the graph be used to determine  $T$ , the period of oscillation of the body?

.....  
.....  
.....  
.....

(2)

A displacement-time graph from simple harmonic motion is drawn below.

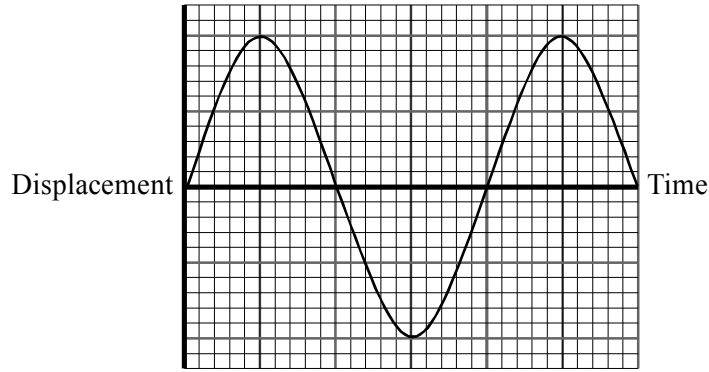

The movement of tides can be regarded as simple harmonic, with a period of approximately 12 hours.

On a uniformly sloping beach, the distance along the sand between the high water mark and the low water mark is 50 m. A family builds a sand castle 10m below the high water mark while the tide is on its way out. Low tide is at 2.00 p.m.

On the graph

- (i) label points L and H, showing the displacements at low tide and the next high tide,
- (ii) draw a line parallel to the time axis showing the location of the sand castle,
- (iii) add the times of low and high tide.

(3)

Calculate the time at which the rising tide reaches the sand castle.

.....

.....

.....

.....

Time .....

(3)

(Total 10 marks)

7. A stone on a string is whirled in a vertical circle of radius 80 cm at a constant angular speed of 16 radians per second.

Calculate the speed of the stone along its circular path.

.....  
.....  
.....

Speed = ..... (2)

Calculate its centripetal acceleration when the string is horizontal.

.....  
.....  
.....

Acceleration = ..... (2)

Calculate the resultant acceleration of the stone at the same point.

.....  
.....  
.....

Resultant acceleration = ..... (3)

Explain why the string is most likely to break when the stone is nearest the ground.

.....  
.....  
.....  
.....

(2)  
**(Total 9 marks)**



8. The diagram shows five pendulums, all suspended from the same string. Pendulum A is displaced by a few centimetres and then released so that it oscillates in a direction perpendicular to the plane of the paper.

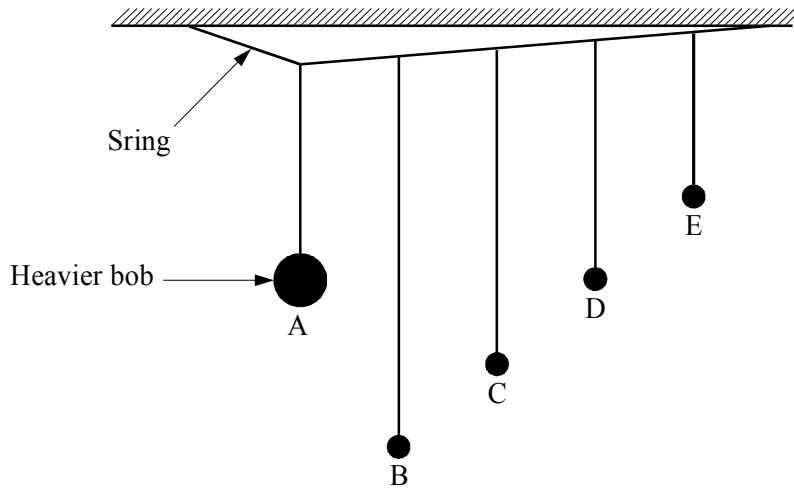

By completing the table below, describe the motion of the pendulums over the next few minutes.

	Frequency compared to frequency of A	Amplitude
A	Constant	
B		
C		
D		
E		

(5)

State what is meant by the term *resonance*. How is resonance demonstrated by this experiment?

.....

.....

.....

.....

.....

(3)

(Total 8 marks)

9. State the period of the Earth about the Sun.

.....

Use this value to calculate the angular speed of the earth about the Sun in  $\text{rad s}^{-1}$ .

.....

.....

Angular speed = .....

(2)

The mass of the Earth is  $5.98 \times 10^{24}$  kg and its average distance from the Sun is  $1.50 \times 10^{11}$  m. Calculate the centripetal force acting on the Earth.

.....

.....

.....

Centripetal force = .....

(2)

What provides this centripetal force?

.....

.....

(1)

(Total 5 marks)

10. What is meant by *simple harmonic motion*?

.....

.....

.....

.....

(2)

Calculate the length of a simple pendulum with a period of 2.0 s.

.....

.....

.....

Length = .....

(2)

The graph shows the variation of displacement with time for a particle moving with simple harmonic motion.

Displacement/cm

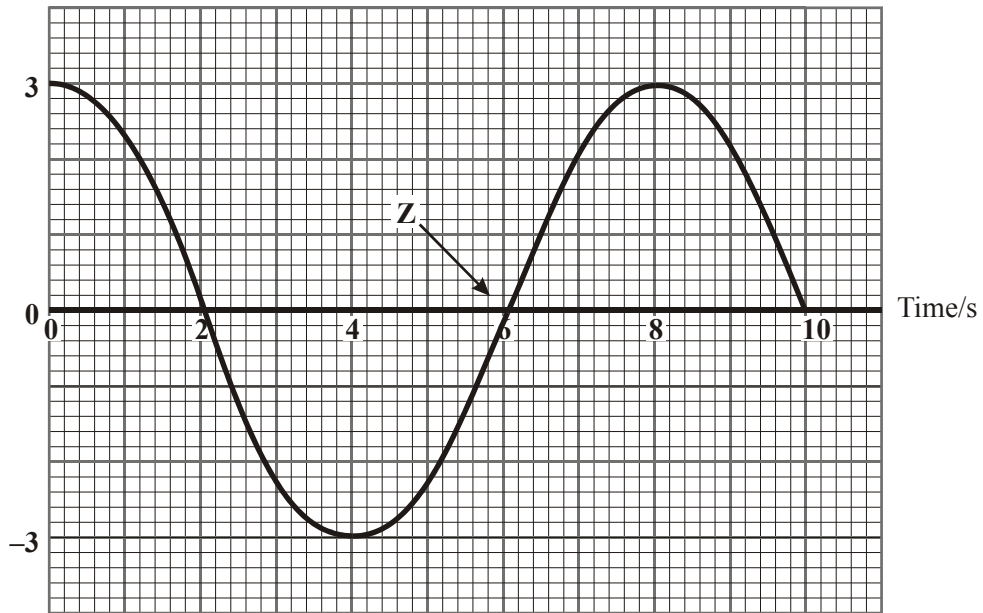

What is the amplitude of the oscillation?

.....

(1)

Estimate the speed of the particle at the point labelled Z.

.....

.....

.....

Speed = .....

(2)

Draw on the axes below a graph of the variation of velocity  $v$  with time for this particle over the same period of time. Add a scale to the velocity axis.

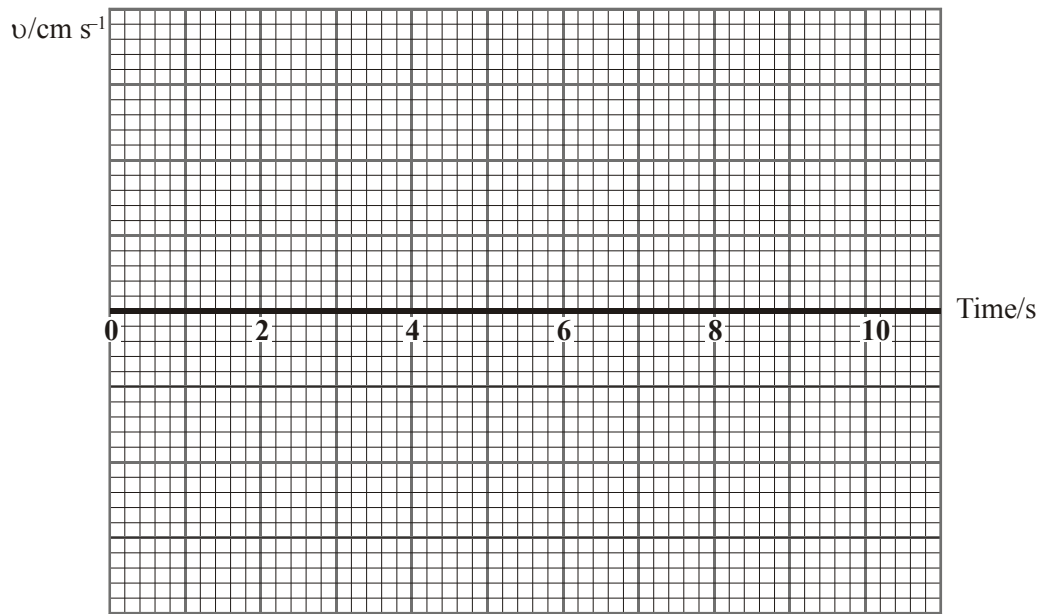

(2)  
(Total 9 marks)

11. One simple model of the hydrogen molecule assumes that it is composed of two oscillating hydrogen atoms joined by two springs as shown in the diagram.

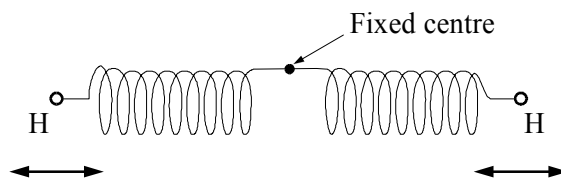

If the spring constant of each spring is  $1.13 \times 10^3 \text{ N m}^{-1}$ , and the mass of a hydrogen atom is  $1.67 \times 10^{-27} \text{ kg}$ , show that the frequency of oscillation of a hydrogen atom is  $1.31 \times 10^{14} \text{ Hz}$ .

.....

.....

.....

.....

(2)

Using this spring model, discuss why light of wavelength  $2.29 \times 10^{-6} \text{ m}$  would be strongly absorbed by the hydrogen molecule.

.....

.....

.....

.....

.....

.....

(4)  
(Total 6 marks)

12. A child of mass 21 kg sits on a swing of length 3.0 m and swings through a vertical height of 0.80 m.

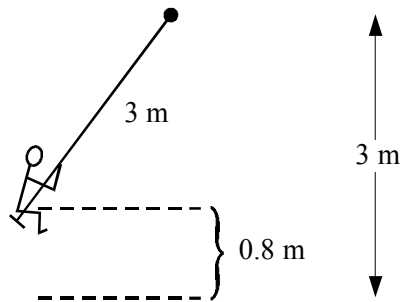

Calculate the speed of the child at a moment when the child is moving through the lowest position.

.....

.....

.....

(2)

Calculate the force exerted on the child by the seat of the swing at a moment when the child is moving through the lowest position.

.....

.....

.....

.....

Force = .....

(3)

Explain why, as the amplitude of the motion increases, children may lose touch with the seat of the swing.

.....

.....

.....

.....

.....

.....

(2)  
(Total 7 marks)

13. Diagram A shows a mass suspended by an elastic cord. The mass is pulled downwards by a small amount and then released so that it performs simple harmonic oscillations of period  $T$ . Diagrams B–F show the positions of the mass at various times during a single oscillation.

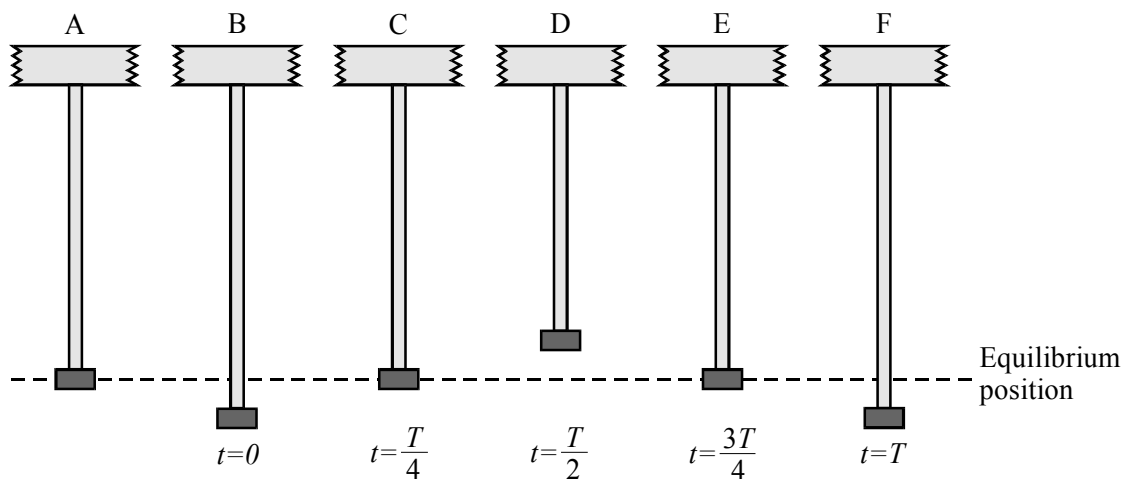

Complete the table below to describe the displacement, acceleration and velocity of the mass at the stages B–F, selecting appropriate symbols from the following list:

- maximum and positive → +
- maximum and negative → -
- zero → 0

Use the convention that *downward* displacements, accelerations and velocities are positive.

(4)

In the sport of bungee jumping, one end of an elastic rope is attached to bridge and the other end to a person. The person then jumps from the bridge and performs simple harmonic oscillations on the end of the rope.

People are bungee jumping from a bridge 50 m above a river. A jumper has a mass of 80 kg and is using an elastic rope of unstretched length 30 m. On the first fall the rope stretches so that at the bottom of the fall the jumper is just a few millimetres above the water.

Calculate the decrease in gravitational potential energy of the bungee jumper on the first fall.

.....  
 .....

Change in g.p.e. = ..... (2)

What has happened to this energy?

..... (1)

Calculate the force constant  $k$ , the force required to stretch the elastic rope by 1 m.

.....  
 .....

Force constant  $k$  = ..... (3)

Hence calculate  $T$ , the period of oscillation of the bungee jumper.

.....  
 .....

Period  $T$  = ..... (2)

(Total 12 marks)

14. The diagram shows a method for determining the mass of small animals orbiting the Earth in Skylab. The animal is securely strapped into a tray attached to the end of a spring. The tray will oscillate with simple harmonic motion when displaced as shown in the diagram and released.

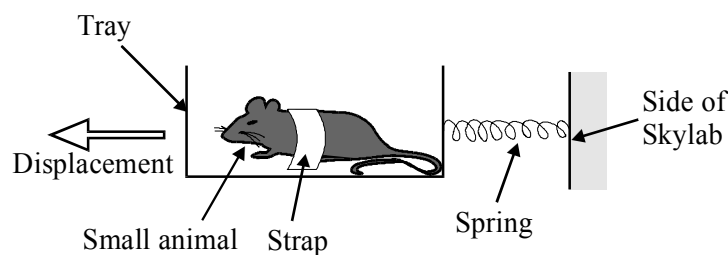

Define *simple harmonic motion*.

.....  
.....  
.....  
.....

(2)

The tray shown above has a mass of 0.400 kg. When it contains a mass of 1.00 kg, it oscillates with a period of 1.22 s.

Calculate the spring constant  $k$ .

.....  
.....  
.....  
.....

$$k = \dots\dots\dots$$

(3)

The 1.00 kg mass is removed and a small animal is now strapped into the tray. The new period of oscillation is 1.48 s. Calculate the mass of the animal.

.....  
.....  
.....

$$\text{Mass} = \dots\dots\dots$$

(2)



The Skylab astronauts suggest that the calibration experiment with the 1.00 kg mass could have been carried out on Earth before take off. If a similar experiment were conducted on Earth would the time period be greater than, less than, or equal to 1.22 s? Explain your answer.

.....

.....

.....

.....

.....

.....

(3)  
(Total 10 marks)

15. The following statements apply to a body orbiting a planet at constant speed and at constant height. Indicate whether each statement is true (✓) or false (✗).

Statement	True/False
The body is travelling at constant velocity.	
The body is in equilibrium because the centripetal force is equal and opposite to the weight.	
The only force acting on the body is its weight.	
The body's acceleration towards the planet equals the gravitational field strength at the position of the body.	

(Total 4)

16. A body performs simple harmonic oscillations. The graph shows how the acceleration of the body varies with time.

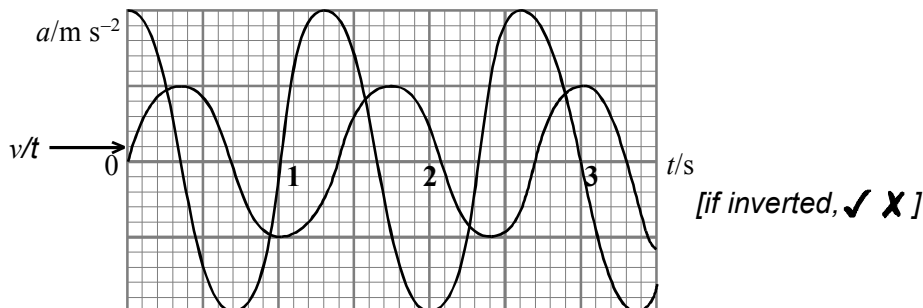

State the frequency of the oscillations.

.....

(1)

Add to the graph above a curve showing how the *velocity* of the same body varies with time over the same period.

(2)

On the grid below, sketch a graph to show how the *force* acting on the same body varies with time over the same period.

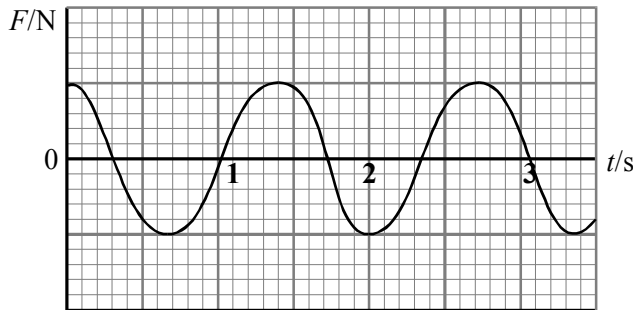

[if inverted, ✓ X]

(2)

A mass  $m$  attached to a spring of force constant  $k$  oscillates with a period of 1.2 s. Calculate the period of oscillation for a mass  $2m$  attached to a spring of force constant  $4k$ .

.....  
 .....  
 .....

Period of oscillation = .....

(2)

(Total 7 marks)

17. The diagram shows one piston of an internal combustion engine.

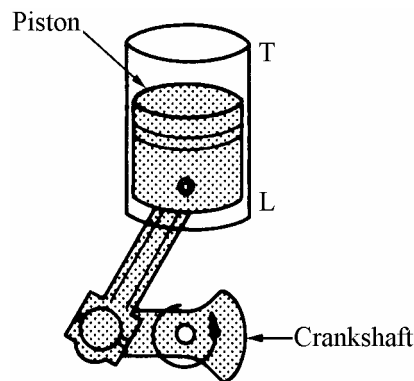

As the crankshaft rotates through  $360^\circ$ , the top of the piston moves from L to T and back to L. The distance LT is 8.6 cm and the crankshaft rotates at 6000 revolutions per minute.

Calculate the frequency of oscillation  $f$  of the piston.

.....

$f =$  .....

(1)

State the amplitude of this oscillation.

.....

(1)

The oscillations of the piston are approximately simple harmonic. Calculate the maximum acceleration of the piston.

.....

.....

.....

Acceleration = .....

At which position(s) in the movement of the piston will this acceleration be zero?

.....

(3)

Suggest why the motion of the piston *is not* perfectly simple harmonic.

.....

(1)

(Total 6 marks)

18. The graph shows the variation of acceleration  $a$  with displacement  $x$  for a body oscillating with simple harmonic motion.

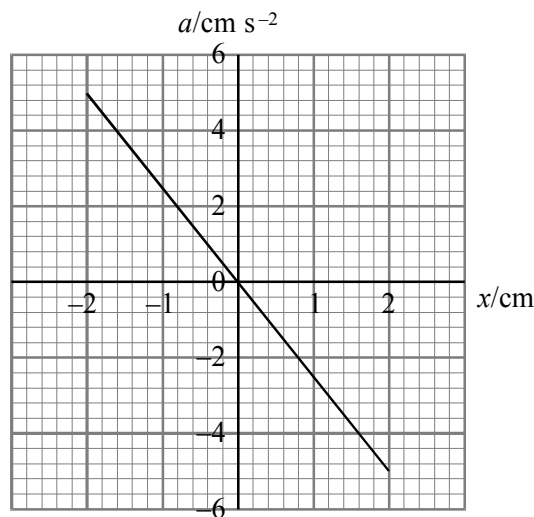

Calculate the period of oscillation of the body.

.....

.....

Period of oscillation = .....

(2)

At time  $t = 0$  the body is momentarily at rest.

On the axes below, sketch a graph to show how acceleration of the body varies with time. Add a scale to the acceleration axis.

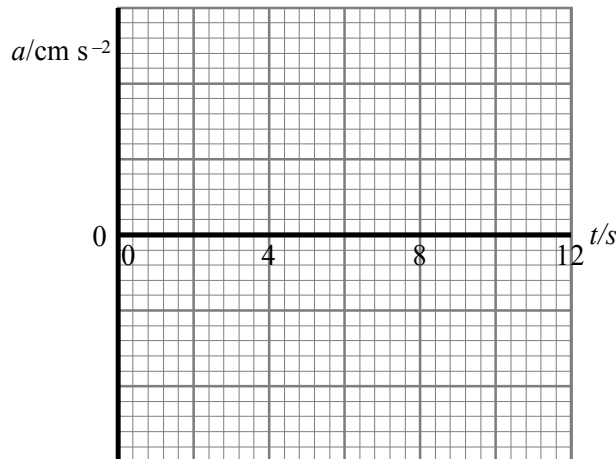

(4)  
(Total 6 marks)

19. A sewing machine needle moves vertically with simple harmonic motion. The difference between the highest and lowest positions of the point of the needle is 3.6 cm. The needle completes 20 stitches per second.

On the grid below sketch a displacement–time graph for the point of the sewing machine needle. Show at least one complete cycle and add a scale to both axes.

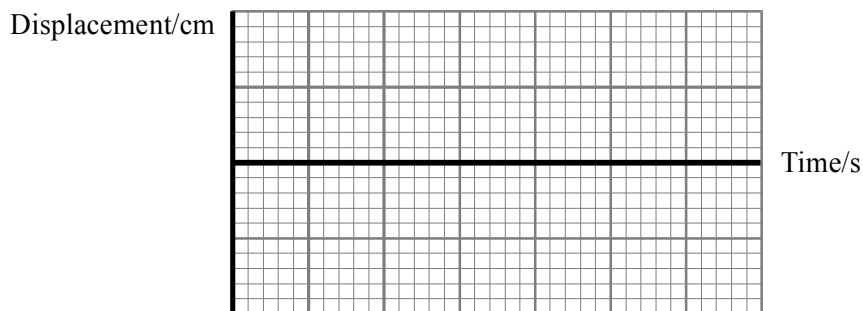

(3)

Calculate the maximum speed of the needle.

.....  
 .....  
 .....

Maximum speed = .....

(2)

On your graph mark with an M two places where the needle moves with this maximum speed.

(1)

(Total 6 marks)

20. An experiment which demonstrates forced vibrations is described below.

Two identical springs are suspended from a rigid support. Spring A carries a mass  $M$  kg while spring B carries a hanger to which slotted masses can be added. The mass of the hanger is much less than  $M$ . The springs are linked by a loosely hanging chain.

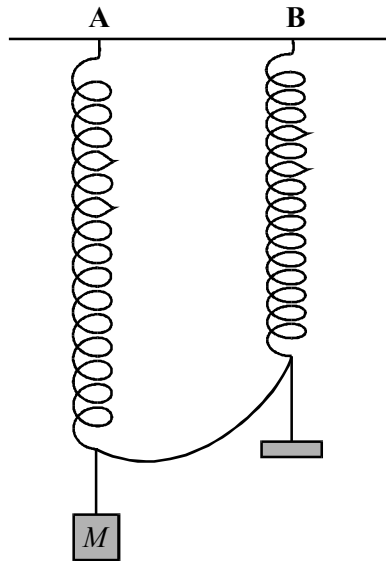

Mass  $M$  is displaced and performs vertical oscillations only. After a few seconds the hanger on spring B is observed to be oscillating vertically with a very small amplitude.

The experiment is repeated several times with an extra mass added to the hanger on spring B each time, until the total mass on B is  $2M$  kg.

Describe and explain the changes to the oscillations of both springs as the mass on B is increased.

.....

.....

.....

.....

.....

.....

.....

.....

.....

.....

(Total 6 marks)

21. Calculate the period  $T$  of a simple pendulum of length 24.9 m.

$T = \dots\dots\dots$

The pendulum is displaced by 3.25 m and allowed to swing freely. Use the equation

$$\text{maximum speed} = 2\pi \times \text{frequency} \times \text{amplitude}$$

to calculate the maximum speed of the pendulum.

.....  
.....

Maximum speed =  $\dots\dots\dots$

Calculate the maximum acceleration of the pendulum.

.....  
.....

Maximum acceleration =  $\dots\dots\dots$

(5)

Sketch two graphs showing how the velocity and the acceleration of the pendulum vary with time.

Each graph should show *two* complete cycles and should start at the same moment in time. Add scales to the axes of both graphs.



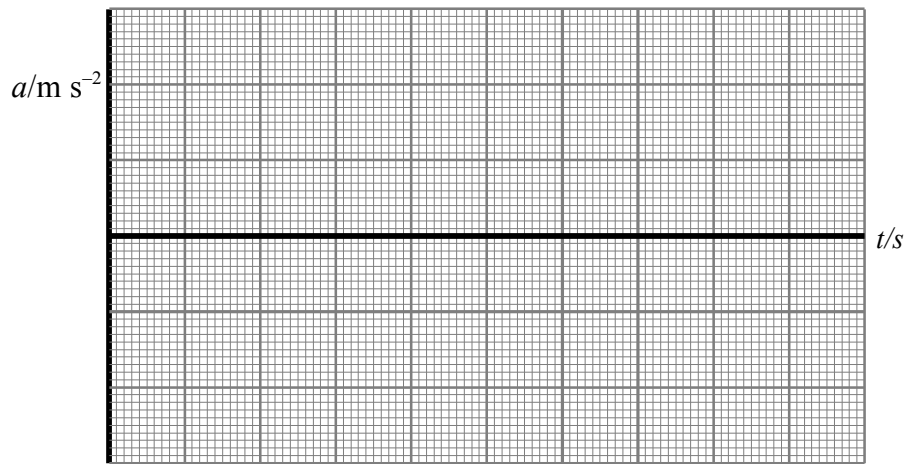

(5)  
(Total 10 marks)

22. A mass moves with simple harmonic motion. The displacement  $x$  of the mass varies with time  $t$  according to the relationship  $x = x_0 \sin 2\pi ft$ .

On the grids provided sketch two graphs, one showing the variation of acceleration of this mass with time, the other showing the variation of acceleration with displacement.

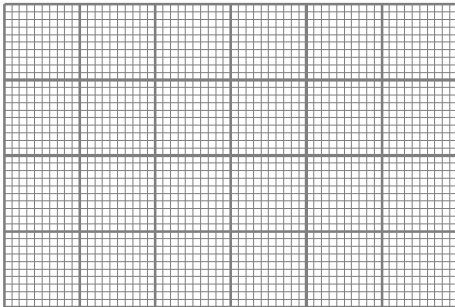

Acceleration – time  
graph

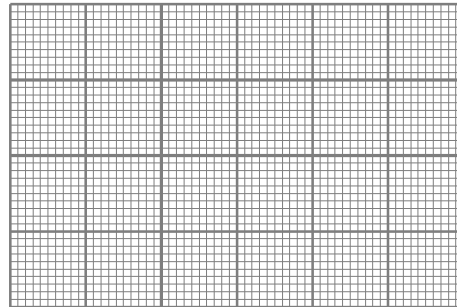

Acceleration – displacement  
graph

(4)

The movement of the tides may be assumed to be simple harmonic with a period approximately equal to 12 hours. The diagram shows a vertical wooden pole fixed firmly to the sea bed. A ring is attached to the pole at point R.

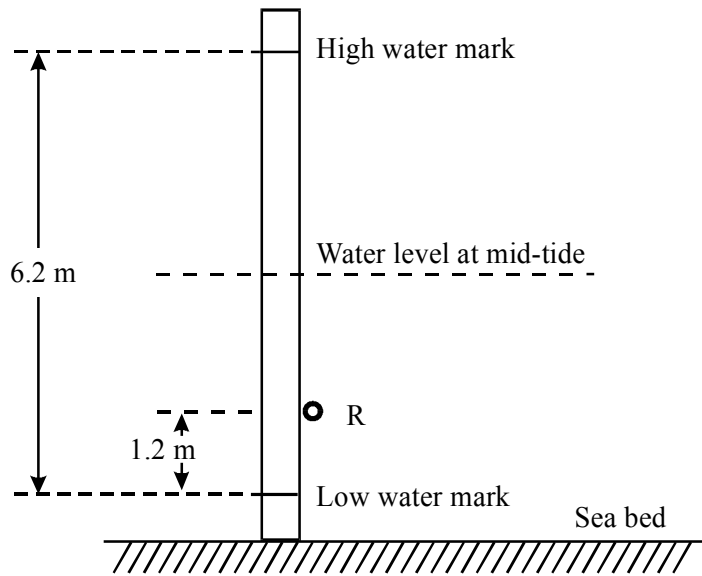

What is the amplitude of this tide?

.....

High tide on a particular day is at 9 a.m. State the times of the next mid-tide and the next low tide.

Next mid-tide: .....

Next low tide: .....

(3)



Calculate the time at which the falling water level reaches the ring R.

.....  
.....  
.....  
.....  
.....  
.....  
.....  
.....  
.....  
.....

Time = .....

**(4)**  
**(Total 11 marks)**

23. Fill in the gaps in the sentences below.

A body oscillates with simple harmonic motion when the resultant force  $F$  acting on it and its displacement  $x$  are related by the expression .....

The acceleration of such a body is always directed .....

The acceleration of the body is a maximum when its displacement is.....

and its velocity is ..... when its displacement is zero.

**(4)**

A mass of 0.08 kg suspended from a vertical spring oscillates with a period of 1.5 s. Calculate the force constant of the spring.

.....  
.....  
.....  
.....

Force constant = .....

**(2)**  
**(Total 6 marks)**

24. A mass is suspended from a spring. The mass is then displaced and allowed to oscillate vertically. The amplitude of the oscillations is 6.0mm. The period of the oscillations is 3.2s.

Calculate the maximum acceleration of the mass.

.....  
.....  
.....

Maximum acceleration = .....

(3)

Sketch a graph showing how the acceleration of the mass varies with displacement. Add a scale to both axes.

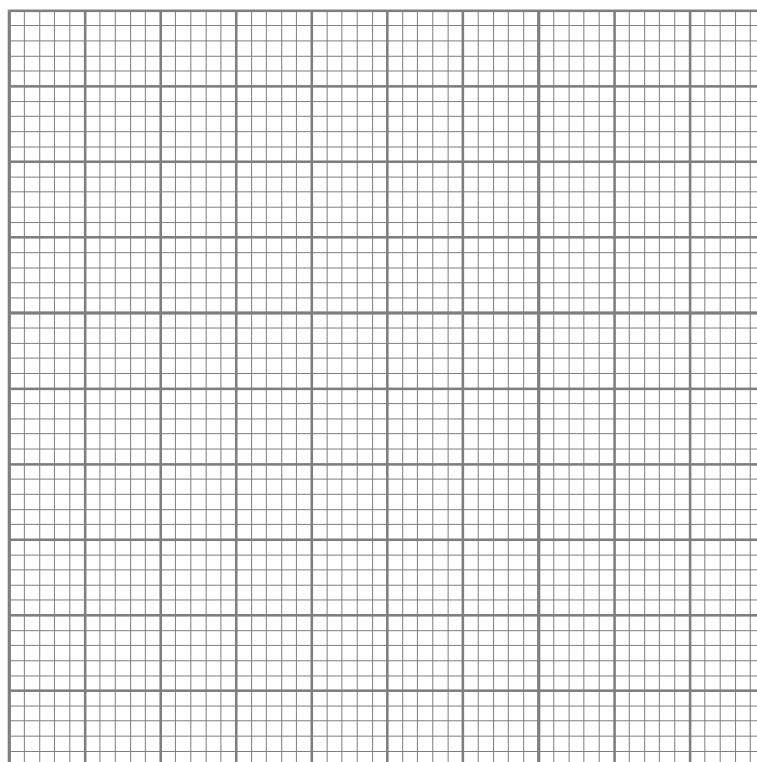

(4)

State and explain *one* reason why the mass may not oscillate with simple harmonic motion.

.....  
.....  
.....

(2)

(Total 9 marks)

25. Explain why a body moving at constant speed in a circular path needs a resultant force acting on it.

.....

.....

.....

.....

(2)

The diagram shows a student at the equator standing on a set of weighing scales, and a free-body force diagram for the student.

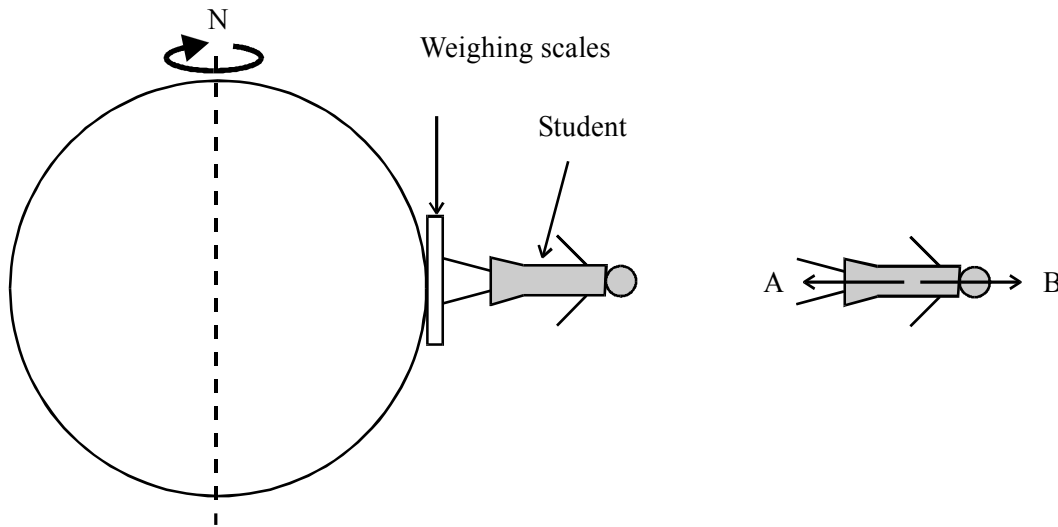

Identify the bodies applying forces A and B.

.....

.....

(2)

Because of the Earth's daily rotation the student is performing circular motion about the Earth's axis. Calculate the angular speed of the student.

.....

.....

.....

Angular speed = .....

(2)

The radius of the Earth is 6400 km. The student's mass is 55 kg. Calculate the resultant force on the student.

.....  
.....  
.....

Resultant force = ..... (3)

Force A is 539 N. Calculate the value of force B.

.....  
.....

Force B = .....

State, with a reason, the force indicated by the weighing scales.

.....  
.....

(3)  
(Total 12 marks)

26. A motorist notices that when driving along a level road at  $95 \text{ km h}^{-1}$  the steering wheel vibrates with an amplitude of 6.0 mm. If she speeds up or slows down, the amplitude of the vibrations becomes smaller

Explain why this is an example of resonance.

.....  
.....  
.....  
.....  
.....

(3)

Calculate the maximum acceleration of the steering wheel given that its frequency of vibration is 2.4 Hz.

.....  
 .....  
 .....  
 .....

Acceleration = .....

(2)  
 (Total 5 marks)

27. A mass of 16 kg is suspended by a spring of spring constant  $k = 3.9 \times 10^3 \text{ N m}^{-1}$ . The mass is displaced downwards and released so that it performs small vertical oscillations.

Calculate the period of the oscillations.

.....  
 .....

Period = .....

(2)

The amplitude of the motion is 8.4 mm. Calculate the maximum acceleration of the mass.

.....  
 .....  
 .....

Maximum acceleration = .....

(3)

Sketch a graph showing how the displacement of the mass would vary with time for the first two cycles. Assume that upward displacements are positive. Add scales to both axes.

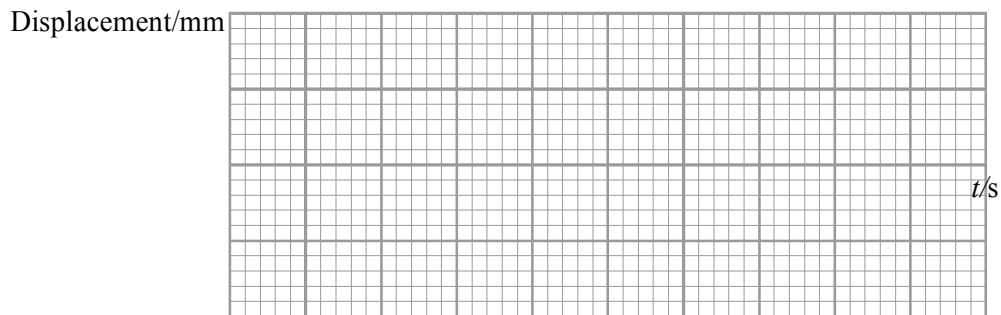

(4)

Sketch on the grid below a displacement-time graph for the same mass if it were moving entirely within motor oil.

Displacement/mm

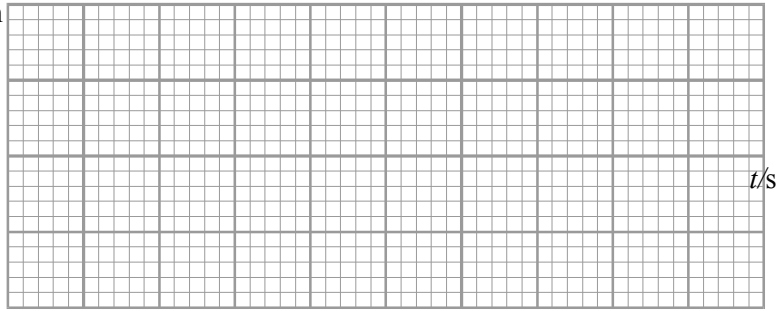

t/s

**(1)**  
**(Total 10 marks)**

1. Complete the diagram below to show the different regions of the electromagnetic spectrum.

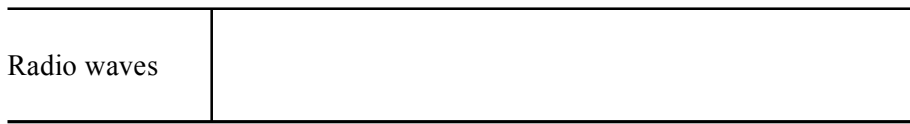

(2)

State *four* differences between radio waves and sound waves.

1. ....
2. ....
3. ....
4. ....

(4)

Two radio stations broadcast at frequencies of 198 kHz and 95.8 MHz. Which station broadcasts at the longer wavelength?

.....

Why do obstacles such as buildings and hills present less of a problem for the reception of the signal from the station transmitting at the longer wavelength?

.....  
.....  
.....  
.....  
.....  
.....

(3)

(Total 9 marks)

2. Describe an experiment using microwaves to produce and detect a two-slit interference pattern.

.....

.....

.....

.....

.....

.....

.....

(4)

Suggest an appropriate slit separation for this experiment.

.....

(1)

How could this experiment be used to obtain a value for the wavelength of the microwaves?

.....

.....

.....

.....

(3)

(Total 8 marks)

3. An experiment using microwaves is set up as shown below.

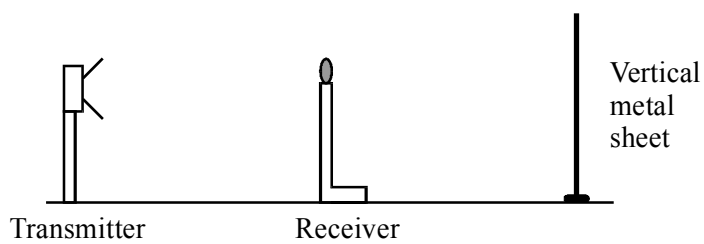



As the receiver is moved slowly towards the metal sheet a number of maxima and minima are detected by the receiver. Explain these observations.

.....

.....

.....

.....

.....

.....

(Total 4 marks)

4. The diagram shows wavefronts spreading out from two identical sources,  $S_1$  and  $S_2$ .

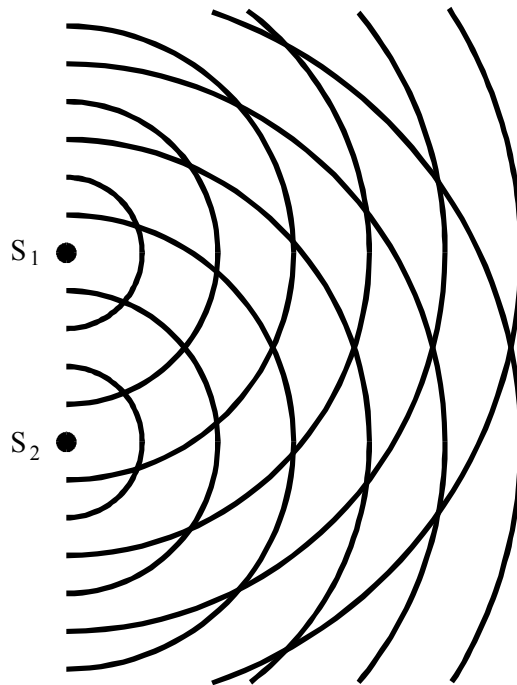

Describe how such a pattern could be produced and observed using a ripple tank.

.....

.....

.....

.....

.....

(5)

On the diagram draw the following:

- (i) a line labelled A joining points where the waves from  $S_1$  and  $S_2$  have travelled equal distances,
- (ii) a line labelled B joining points where the waves from  $S_1$  have travelled one wavelength further than the waves from  $S_2$ ,
- (iii) a line labelled C joining points where the waves from  $S_2$  have travelled half a wavelength further than the waves from  $S_1$ .

(4)

Complete each of the sentences below by selecting an appropriate term from the following:

- increase
- decrease
- stay the same

If only the separation of the sources were increased, the angle between lines A and B would.....

If only the wavelength of the waves were increased, the angle between lines A and B would.....

If only the depth of the water in the ripple tank were increased, the angle between lines A and B would.....

(3)  
(Total 12 marks)

5. A laser beam of wavelength 690 nm is directed normally at parallel slits as shown below.

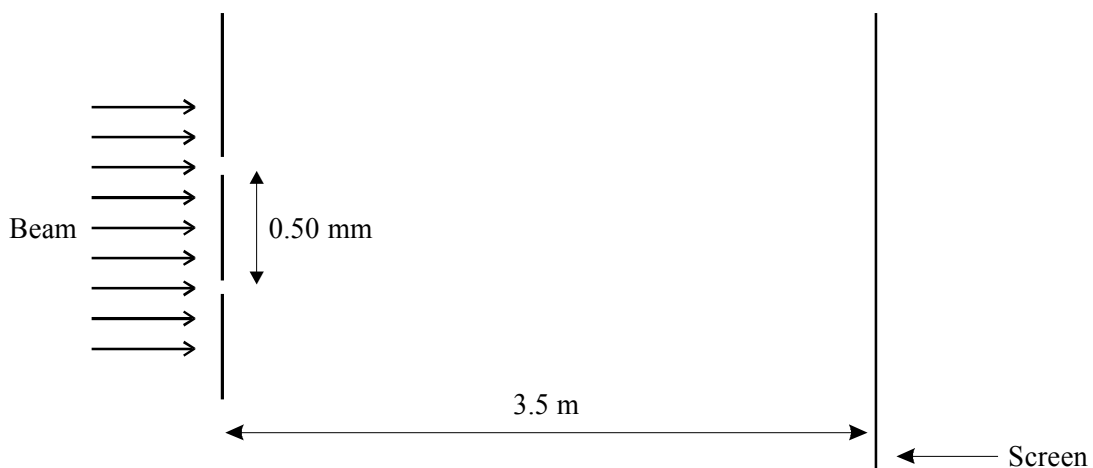

Calculate the fringe spacing at the screen.

.....  
.....  
.....

Fringe spacing = .....

Sketch the pattern which would be observed on the screen.

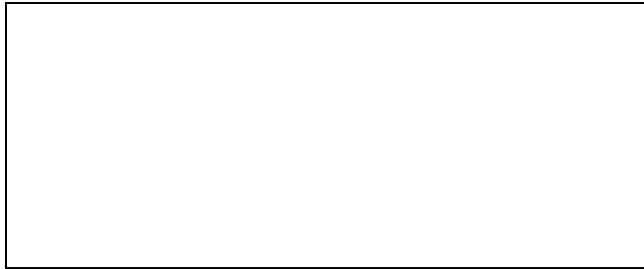

(4)

This laser beam is replaced by one with a wavelength of 460 nm. Describe how the appearance of the fringes would change.

.....  
.....  
.....

(2)

The two laser beams are now directed simultaneously at the slits. Which fringes exactly overlap?

.....  
.....  
.....

(2)

**(Total 8 marks)**

6. Monochromatic light of constant intensity falls on a photocell. The graph shows how the current in the photocell varies with the potential difference applied across it.

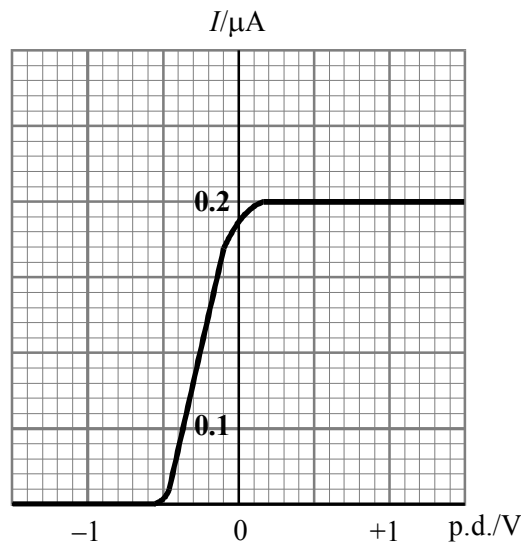

The frequency of the incident light is  $6.0 \times 10^{14}$  Hz. Use the graph to estimate the work function of the metal which forms the cathode of the photocell.

.....

.....

.....

.....

.....

Work function = .....

(3)

Add to the axes above the graph obtained when only the intensity of the light is increased. Label this graph A.

Add to the axes above the graph obtained when only the frequency of the light is increased. Label this graph B.

(4)

(Total 7 marks)

7. Under what circumstances could two progressive waves produce a stationary (standing) wave?

.....

.....

.....

.....

(2)

Describe with the aid of a diagram an experiment using microwaves to produce stationary (standing) waves.

.....

.....

.....

How would you show that a stationary wave had been produced?

.....

.....

.....

(3)  
(Total 5 marks)

8. The diagram shows part of a stretched slinky spring and the same section of the spring when a longitudinal wave is travelling along it.

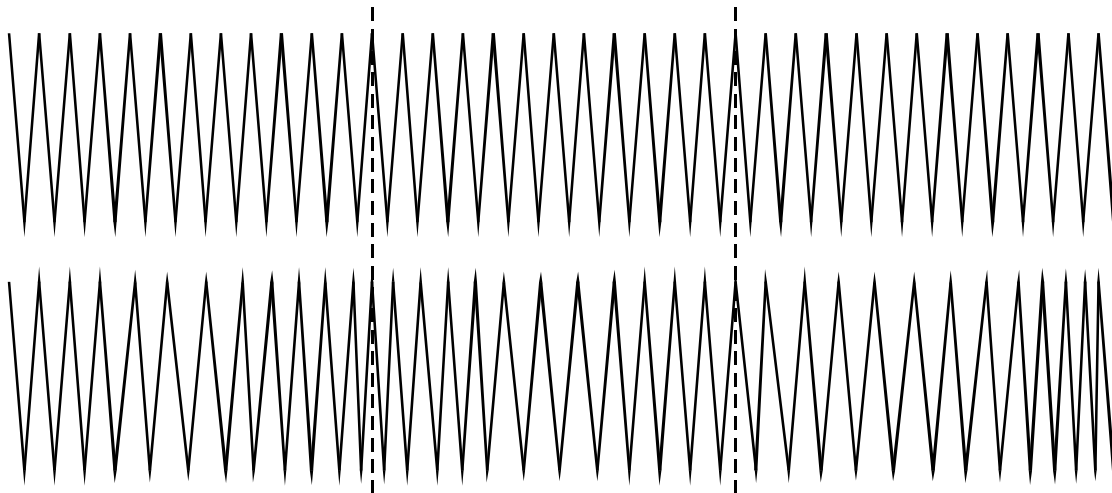

The dotted vertical lines show the positions of two coils which at this moment are undisplaced.

Mark on the lower diagram a compression C and a rarefaction R

Measure the wavelength of the wave

Wavelength .....

Mark on the lower diagram a coil with maximum displacement, M.

Measure the amplitude of the wave, i.e. the displacement of coil M.

Amplitude .....

**(Total 4 marks)**

9. The diagram shows apparatus which can be used to demonstrate the photoelectric effect.

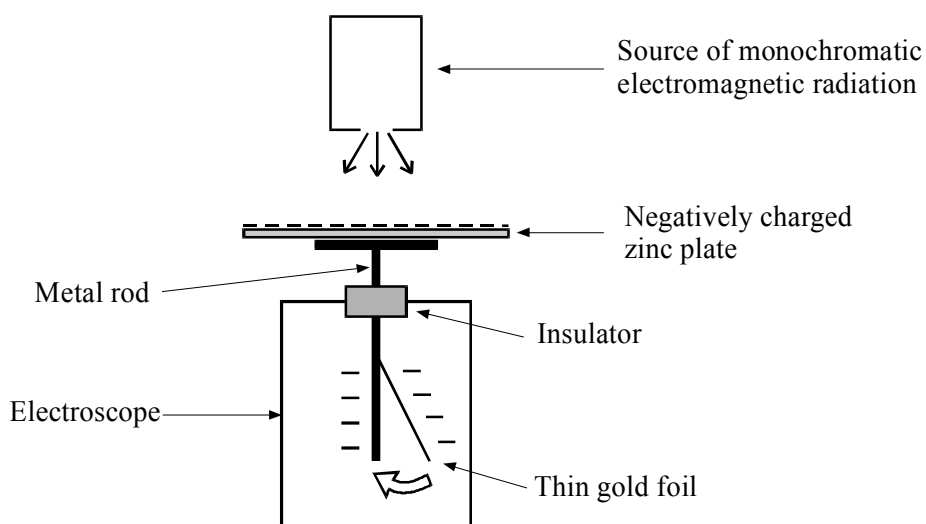

The deflection of the thin gold foil is a measure of the charge stored on the zinc plate.

When ultraviolet light is directed towards the zinc plate, the thin gold foil gradually returns to the vertical.

When red light is used the thin gold foil stays in the position shown.

How does the particle theory of light explain these observations?

.....

.....

.....

.....

.....

.....

.....

.....

.....

.....

.....

.....

.....

.....

.....

(4)

What would be observed if electromagnetic radiation of greater intensity were used?

Ultraviolet of greater intensity .....

.....

Red light of greater intensity .....

.....

(2)

What would be observed if the zinc plate and electroscope were positively charged? Explain your answer.

.....

.....

.....

.....

(2)

(Total 8 marks)

10. The diagram shows some of the energy levels for atomic hydrogen.

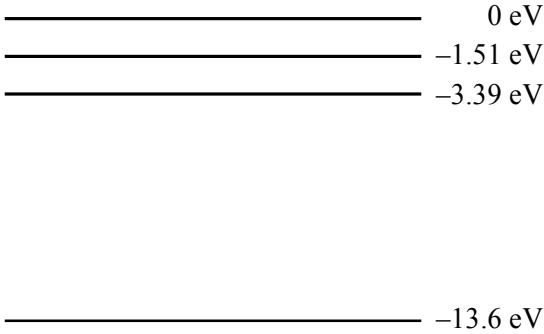

Add arrows to the diagram showing all the single transitions which could ionise the atom.

(2)

Why is the level labelled  $-13.6\text{eV}$  called the ground state?

.....  
.....  
.....

**(1)**

Identify the transition which would result in the emission of light of wavelength  $660\text{ nm}$ .

.....  
.....  
.....  
.....

Transition = .....

**(4)**

**(Total 7 marks)**

11. A  $60\text{ W}$  filament lamp transfers electrical energy to light with an efficiency of  $12\%$ . Calculate the light intensity produced by the lamp at a point  $3.5\text{ m}$  from the filament.

.....  
.....  
.....  
.....

Intensity =.....

**(3)**

The lamp is observed through a sheet of Polaroid.

Describe and explain the effect of this on the intensity of the light.

.....  
.....  
.....  
.....  
.....



The sheet of Polaroid is now slowly rotated in a plane perpendicular to the direction of propagation of the light. What effect does this have on the intensity of the light?

.....  
 .....

(4)  
 (Total 7 marks)

12. A beam of microwaves is directed at two slits in a metal sheet. The diagram below shows two adjacent positions P and R where a microwave detector would register maximum readings.

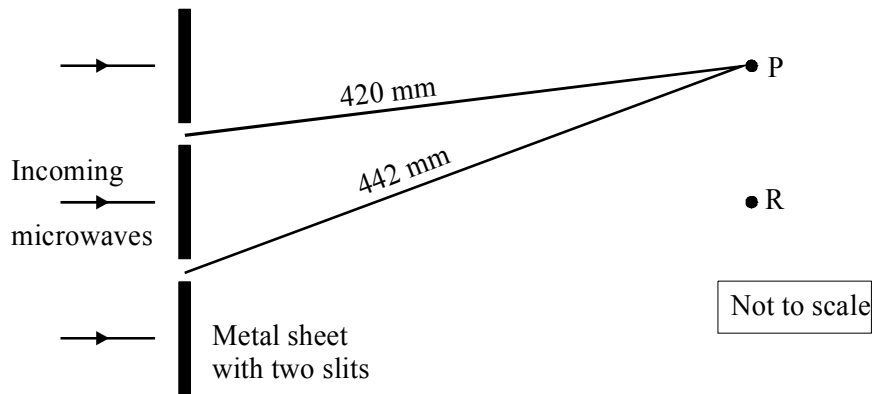

Use the diagram to determine the wavelength of the microwaves.

.....  
 .....

Wavelength = .....

Calculate the frequency of the microwaves.

.....  
 .....

Frequency = .....

(4)

On the diagram mark with a Q a position where another maximum reading would occur. On the diagram mark with a D a position where a minimum reading would occur.

(2)

In a similar experiment, sound waves were directed at the same metal sheet. The speed of sound is  $330\text{ms}^{-1}$  and the frequency of the sound waves was  $1100\text{Hz}$ . Explain why a maximum reading would *not* be detected at P in this experiment.

.....

.....

.....

.....

(2)  
(Total 8 marks)

13. Draw a labelled diagram of the apparatus you would use to produce a two slit interference pattern with light.

State appropriate values for

- (i) the slit separation

.....

- (ii) the distance from the slits to the screen.

.....

(3)

The photograph shows an interference pattern obtained from such an experiment using monochromatic light.

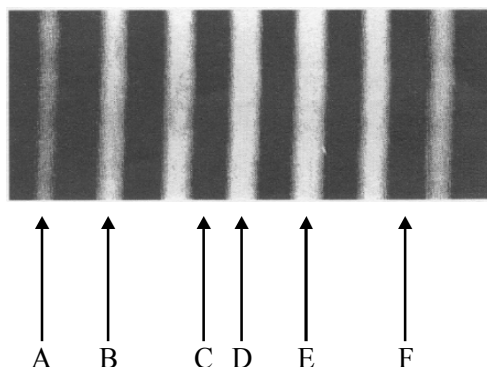

scale 1:1

Determine the fringe width.

.....  
 .....

Fringe width = .....

(2)

Complete the following sentences by adding one or more of the letters A-F, shown on the diagram.

Light from the two slits has travelled the same distance at position(s) .....

Light from the two slits is out of phase at position(s) .....

There is a path difference of three wavelengths between light from the two slits at position(s) .....

(4)

One of the slits is now covered. Describe how the pattern on the screen changes.

.....  
 .....  
 .....  
 .....  
 .....

(2)

(Total 11 marks)

14. A student devises a way of measuring electric current by hanging a mass of 50 g on a conducting wire stretched between two points P and Q which are 2.40 m apart. The sag at the centre of the wire varies with the current  $I$ , as the wire expands because of the heating effect of the current. The sag is 0.070 m when the current is 13 A d.c.

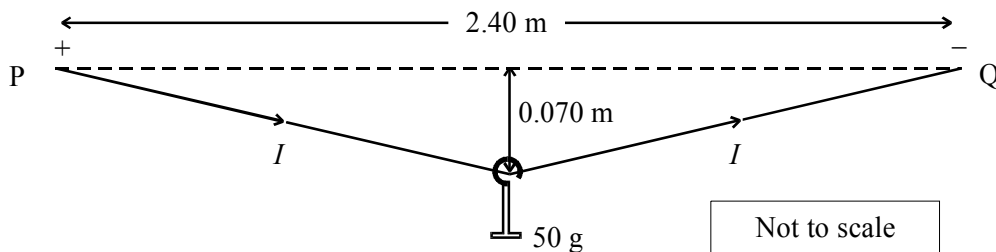

- (a) Draw a free-body force diagram for the 50 g mass when the sag is 0.070 m. Hence, or otherwise, determine the tension  $T$  in the wire. (5)
- (b) Outline how the student could have measured the resistance of the conducting wire at different values of  $I$  before setting up this experiment. (3)
- (c) The student now connects P and Q to a 50 Hz a.c. supply. When the current is 13 A r.m.s. the wire is found to oscillate as shown.

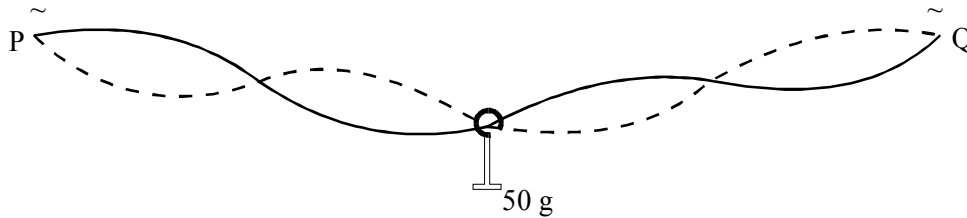

The student measures the distance between adjacent nodes along the wire to be 606 mm.

- (i) What is meant by a current of 13 A r.m.s.?
- (ii) Deduce the speed  $c$  of transverse waves along the hot wire.
- (iii) Suggest why the wire oscillates in this manner. (6)
- (d) The tension in the wire is related to  $c$  and the mass per unit length  $\mu$  of the wire by the expression

$$T = \mu c^2$$

Show that the unit of  $\mu c^2$  is N.

(2)  
(Total 16 marks)

15. Complete the diagram below to show the different regions of the electromagnetic spectrum.

Radio waves		γ-rays
-------------	--	--------

(1)

State *four* differences between radio waves and sound waves.

- 1 .....
- 2 .....
- 3 .....
- 4 .....

(4)

Two radio stations broadcast at frequencies of 198 kHz and 95.8 MHz. Which station broadcasts at the longer wavelength?

.....

Why do obstacles such as buildings and hills present less of a problem for the reception of the signal from the station transmitting at the longer wavelength?

.....  
.....  
.....  
.....  
.....  
.....

**(3)**  
**(Total 8 marks)**

- 16.** Draw a labelled diagram of the microwave apparatus you would use to produce and detect a two-slit interference pattern.

**(3)**

Suggest an appropriate slit separation for this experiment.

.....

**(1)**

How could this experiment be used to obtain a value for the wavelength of the microwaves?

.....

.....

.....

.....

.....

.....

(3)  
(Total 7 marks)

17. The diagram shows a water skier being pulled at a steady speed in a straight line. Her mass plus the mass of the ski is 65 kg. The pull of the tow-rope on her is 520 N.

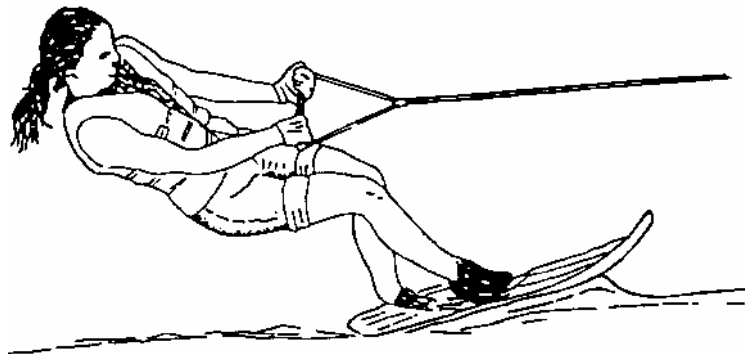

- (a) (i) What are the horizontal and vertical components  $X$  and  $Y$  of the push of the water on the ski? (Ignore air resistance.)
- (ii) Her weight and the 520 N towing force exert moments around the point on the ski through which the resultant of  $X$  and  $Y$  act.

Explain how she can remain in equilibrium as she is towed along if the size of the towing force varies.

(4)

- (b) Later, while still being towed, she moves in a curved path from behind the boat to approach a ramp from which she makes a jump, remaining in the air for over two seconds.

Describe the force which enables her to accelerate centripetally as she moves in a curved path.

Why does she feel “weightless” while in the air during her jump?

(3)

- (c) After her jump she again moves with her original velocity, experiencing a towing force of 520 N. Suddenly, she lets go of the tow-rope. Calculate her initial deceleration. Why does her deceleration reduce as she slows down?

(3)

- (d) An observer notices that the waves she produces approaching the shore diffract as they pass through a gap leading to a boatyard. The diffraction of electro-magnetic waves is involved when we collect information about stars and galaxies.

Explain how light diffracted through gratings can yield information about distant stars and galaxies. You may be awarded a mark for the clarity of your answer.

**(5)**

**(Total 15 marks)**

18. The diagram is a plan view of an experiment to measure the wavelength of microwaves. The diagram is to scale but **one third of full size**.

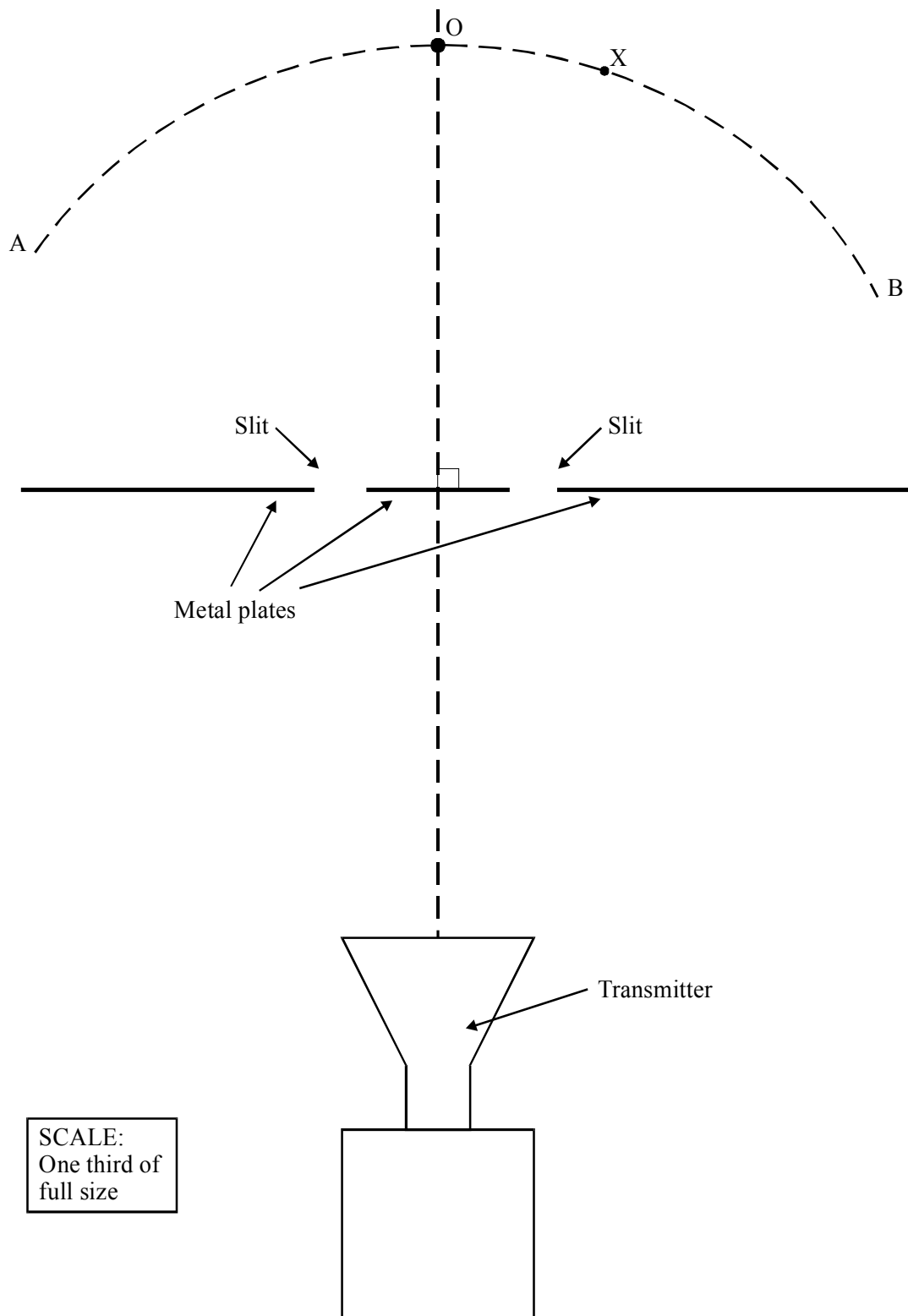



As a microwave detector is moved around the arc from A to B, alternate maxima and minima of intensity are observed. Explain why.

.....

.....

.....

.....

.....

.....

.....

.....

(4)

A maximum is observed at point O, and the next maximum at point X. By means of suitable measurements on the diagram determine the wavelength of the microwaves.

.....

.....

.....

.....

.....

Wavelength = .....

(3)

A teacher demonstrating this experiment finds that, even at the maxima, the wave intensity is small. A student suggests making the slits wider to let more energy through. Explain why this might not be a good idea.

.....

.....

.....

.....

(2)

For an interference pattern to be observed between waves from two sources, the sources must be coherent. Explain what is meant by **coherent**, and what makes the two sources in this experiment coherent.

.....

.....

.....

.....

.....

(2)  
(Total 11 marks)

19. A laser emits green light of wavelength 540 nm. The beam is directed onto a pair of slits as shown.

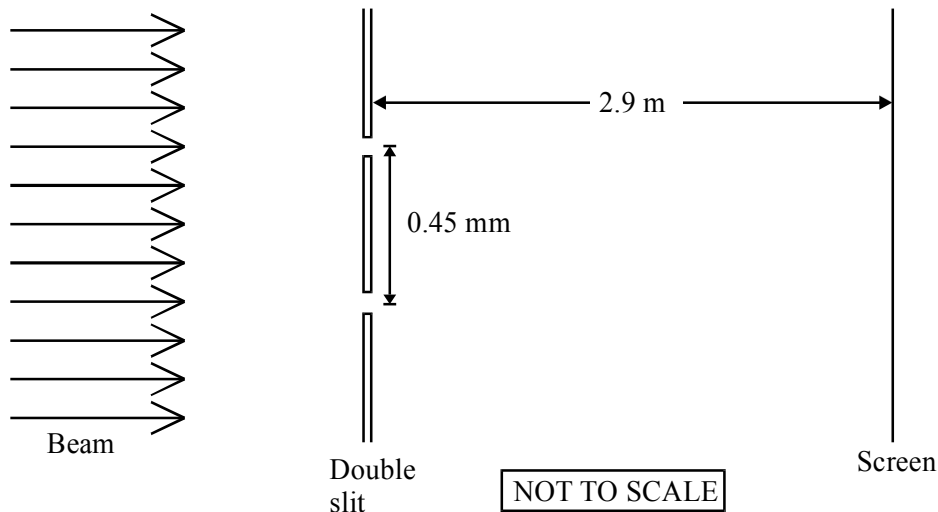

The light from the two slits superposes on the screen forming an interference pattern. Calculate the fringe separation.

.....

.....

.....

Fringe separation = .....

(2)

Without any further calculation, state what would happen to the fringe separation if, **separately**,

- (i) the slit separation were reduced,

.....

(ii) the distance from the slits to the screen were increased,

.....

(iii) the laser were replaced with one which emitted red light.

.....

(3)

Draw in the space below the diffraction pattern you would observe if **one** of the slits were covered up.

(3)  
(Total 8 marks)

20. The diagram shows, not to scale, an experimental arrangement for studying the transmission of light by a double slit.

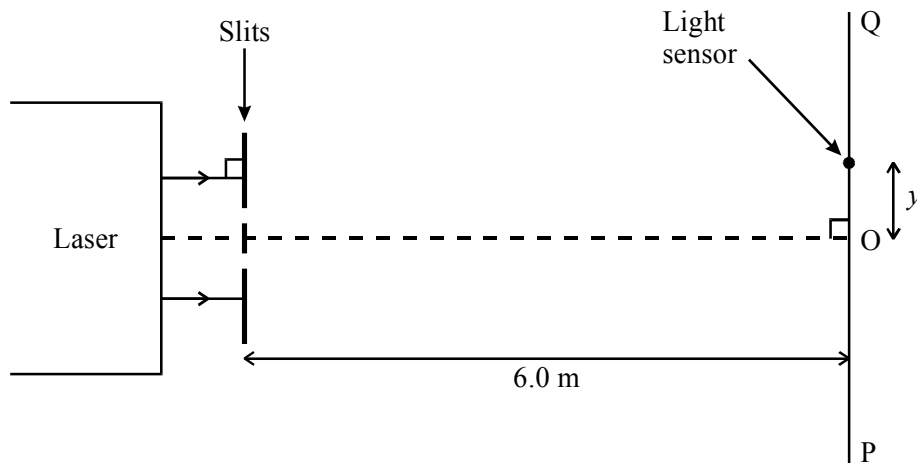

Monochromatic light from a laser falls normally on two narrow, closely spaced parallel slits. The intensity of light transmitted is studied by moving a small light sensor along the line PQ, at a perpendicular distance of 6.0 m from the slits. The graph shows how the light intensity varies with distance  $y$  from the mid-point O.

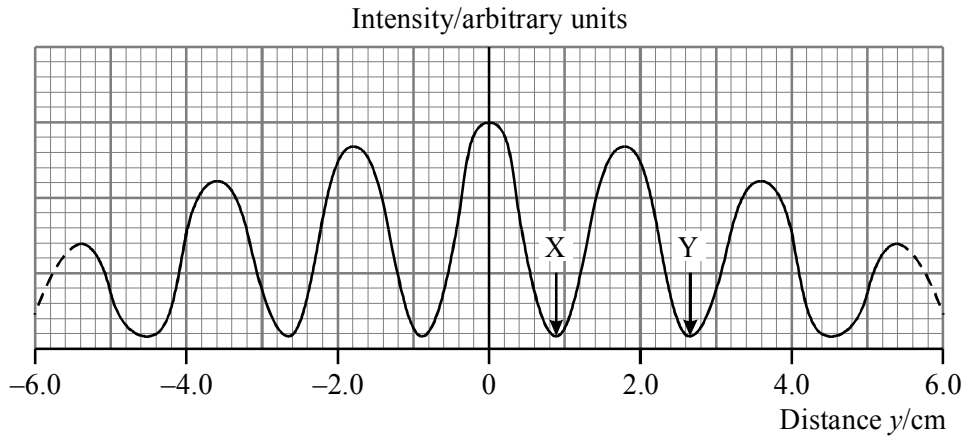

Explain with the aid of a diagram why the two light waves from the slits produce a minimum intensity at X.

.....  
 .....  
 .....

(2)

Point O is equidistant from the slits. State, in terms of the wavelength  $\lambda$ , the path difference between the waves arriving at Y.

Path difference = .....

What is the phase difference, in radians, between the waves arriving at point Y?

.....

Phase difference = ..... rad.

(2)

The spacing of the slits in the experiment was 0.20 mm. Use this, together with information from the diagrams, to calculate the wavelength of the light.

.....  
.....  
.....  
.....

Wavelength = .....

**(3)**

One of the two slits is now covered up and the experiment is repeated. Add a line to the graph opposite to show how you would expect the light intensity to vary with the distance  $y$ .

**(2)**

**(Total 9 marks)**

**21.** Describe with the aid of a diagram how you could produce stationary waves on a string.

.....  
.....  
.....  
.....

**(3)**

Explain how you could use a stationary wave to determine the speed of travelling waves on the string. You may be awarded a mark for the clarity of your answer.

.....

.....

.....

.....

.....

.....

(4)  
(Total 7 marks)

22. A piece of string is connected to a variable frequency vibration generator. The fundamental frequency of this system is 60 Hz.

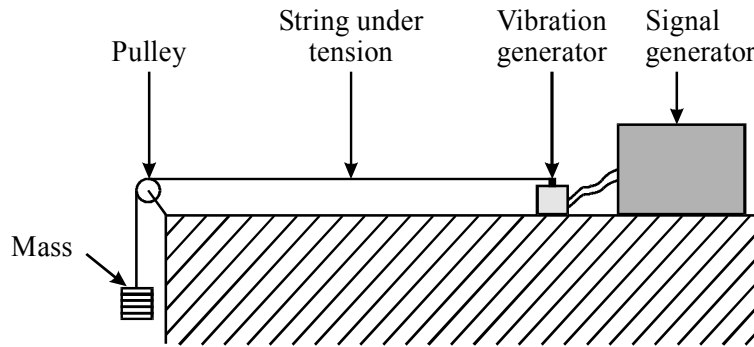

Complete the table to show what would be observed as the frequency is gradually increased from 40 Hz to 180 Hz.

Frequency / Hz	Relative maximum amplitude	Appearance of string
40	low	
60	high	
100		
120		
180		

(7)

How is this phenomenon used to describe the behaviour of the electron in a hydrogen atom? You may be awarded a mark for the clarity of your answer.

.....

.....

.....

.....

.....

.....

.....

(4)  
(Total 11 marks)

23. Each of the diagrams below shows a series of wavefronts, one wavelength apart, approaching a gap between two barriers in a ripple tank.

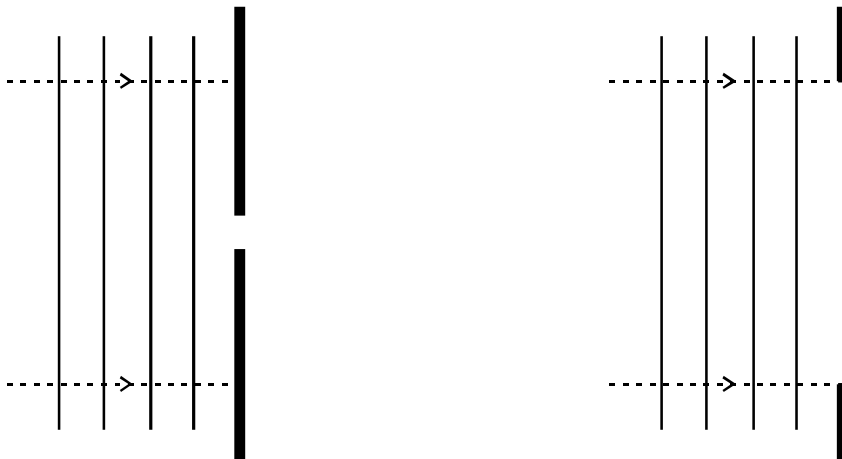

What is a wavefront?

.....

.....

(1)

Add further wavefronts to each diagram to show what happens as the waves pass through each gap.

(3)

The station BBC Radio 4 broadcasts both on the Long Wave band at 198 kHz and on VHF at approximately 94 MHz. In mountainous parts of the country, reception is better on Long Wave than on VHF. Suggest why.

.....

.....

.....

.....

(2)  
(Total 6 marks)

24. In an experiment on superposition, light from a laser was incident normally on a double slit, and the interference pattern was observed on a screen situated a distance  $D$  from the slits. The fringe spacing  $x$  was measured for a number of different values of  $D$  and the graph below was plotted.

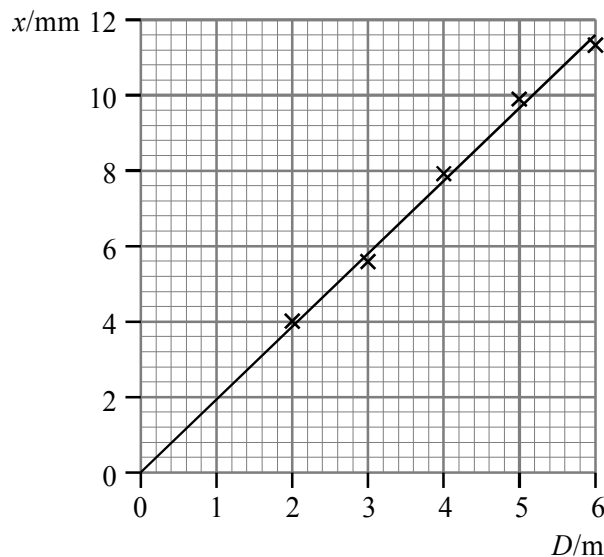

Determine the gradient of the graph.

.....

.....

Gradient = .....

(1)



Use your result to find a value for the spacing of the slits, given that the wavelength of the light was 620 nm.

.....  
.....  
.....  
.....

Slit spacing = .....

(2)

Add a second line to the graph to show the results you would expect if the experiment were repeated with the slit spacing doubled.

(1)

**(Total 4 marks)**

1. (a) The following equation describes the release of electrons from a metal surface illuminated by electromagnetic radiation.

$$hf = k.e._{\max} + \phi$$

Explain briefly what you understand by each of the terms in the equation.

$hf$  .....

.....

$k.e._{\max}$  .....

.....

$\phi$  .....

.....

(3)

- (b) Calculate the momentum  $p$  of an electron travelling in a vacuum at 5% of the speed of light.

.....

.....

.....

$$p = \dots\dots\dots$$

(3)

What is the de Broglie wavelength of electrons travelling at this speed?

.....

.....

.....

$$\lambda = \dots\dots\dots$$

(2)

Why are electrons of this wavelength useful for studying the structure of molecules?

.....

.....

.....

(2)

(Total 10 marks)

-

2. A 60 W light bulb converts electrical energy to visible light with an efficiency of 8%. Calculate the visible light intensity 2 m away from the light bulb.

.....  
.....  
.....

Intensity = .....

(3)

The average energy of the photons emitted by the light bulb in the visible region is 2 eV. Calculate the number of these photons received per square metre per second at this distance from the light bulb.

.....  
.....  
.....

Number of photons = .....m<sup>-2</sup> s<sup>-1</sup>

(2)

(Total 5 marks)

3. (a) Describe briefly how you would demonstrate in a school laboratory that different elements can be identified by means of their optical spectra

.....  
.....  
.....  
.....  
.....

(3)

- (b) The diagram below is a simplified energy level diagram for atomic hydrogen.

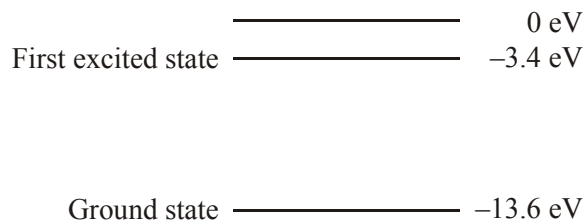

A free electron with kinetic energy 12 eV collides with an atom of hydrogen and causes it to be raised to its first excited state.

Calculate the kinetic energy of the free electron (in eV) after the collision.

.....  
 .....

Kinetic energy = .....

Calculate the wavelength of the photon emitted when the atom returns to its ground state.

.....  
 .....

Wavelength = .....

(4)  
 (Total 7 marks)

4. The graph shows how the maximum kinetic energy  $T$  of photoelectrons emitted from the surface of sodium metal varies with the frequency  $f$  of the incident radiation.

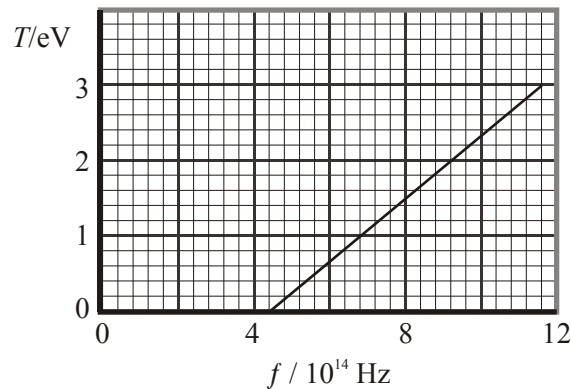

Why are no photoelectrons emitted at frequencies below  $4.4 \times 10^{14}$  Hz?

.....  
 .....

(1)

Calculate the work function  $\phi$  of sodium in eV.

.....  
 .....

Work function = .....

(3)

Explain how the graph supports the photoelectric equation  $hf = T + \phi$

.....  
 .....  
 .....

(2)

How could the graph be used to find a value for the Planck constant?

.....  
 .....

(1)

Add a line to the graph to show the maximum kinetic energy of the photoelectrons emitted from a metal which has a greater work function than sodium.

(2)

**(Total 9 marks)**

5. The diagram shows some of the outer energy levels of the mercury atom.

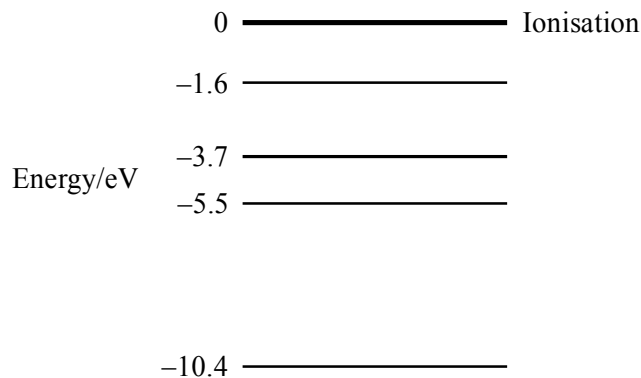

Calculate the ionisation energy in joules for an electron in the -10.4 eV level.

.....  
 .....

Ionisation energy = .....

(2)

An electron has been excited to the -1.6 eV energy level. Show on the diagram all the possible ways it can return to the -10.4 eV level.

(3)

Which change in energy levels will give rise to a yellowish line ( $\lambda = 600 \text{ nm}$ ) in the mercury spectrum?

.....  
.....  
.....  
.....  
.....

(4)  
(Total 9 marks)

6. Explain what is meant by the term *wave-particle duality*.

.....  
.....  
.....  
.....  
.....  
.....

(3)

Calculate the de Broglie wavelength of a snooker ball of mass  $0.06 \text{ kg}$  travelling at a speed of  $2 \text{ m s}^{-1}$

.....  
.....

Wavelength = .....

(2)

Comment on your answer.

.....  
.....

(1)  
(Total 6 marks)

7. The diagram shows some of the energy levels for atomic hydrogen.

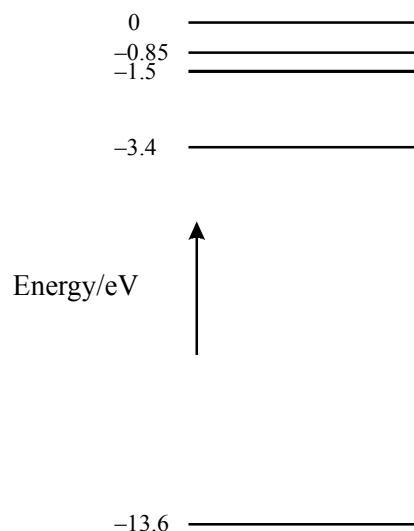

For each of the statements below, indicate whether the statement is true (✓) or false (✗).

Statement	True/False
The single electron of a hydrogen atom normally occupies the $-13.6$ eV energy level.	
An electron of energy $10$ eV colliding with a hydrogen atom in its ground state could have an energy of $0.2$ eV after the collision.	
An electron moving from the $-3.4$ eV to the $-0.85$ eV level gives out a photon of energy $2.55$ eV.	
Light of wavelength $650$ nm has sufficient energy to excite an electron from the $-3.4$ eV to the $-1.5$ eV energy level.	

Use this space for any calculations.

**(4)**  
**(Total 4 marks)**

8. Experiments on the photoelectric effect show that

- the kinetic energy of photoelectrons released depends upon the frequency of the incident light and not on its intensity,
- light below a certain threshold frequency cannot release photoelectrons.

How do these conclusions support a particle theory but not a wave theory of light?

.....

.....

.....

.....

.....

(6)

Calculate the threshold wavelength for a metal surface which has a work function of 6.2 eV.

.....

.....

.....

.....

Threshold wavelength = .....

To which part of the electromagnetic spectrum does this wavelength belong?

.....

(4)

(Total 10 marks)

19. The diagram shows monochromatic light falling on a photocell.

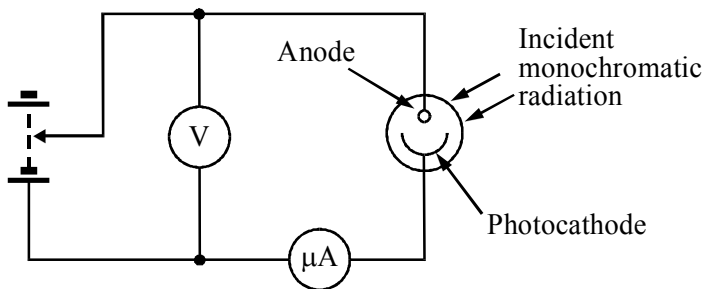

As the reverse potential difference between the anode and cathode is increased, the current measured by the microammeter decreases. When the potential difference reaches a value  $V_s$ , called the stopping potential, the current is zero.



Explain these observations.

.....

.....

.....

.....

.....

.....

(5)

What would be the effect on the stopping potential of

(i) increasing only the intensity of the incident radiation,

.....

(ii) increasing only the frequency of the incident radiation?

.....

(2)

(Total 7 marks)

10. A muon is a particle which has the *same charge* as an electron but its *mass* is 207 times the mass of an electron.

An unusual atom similar to hydrogen has been created, consisting of a muon orbiting a single proton. An energy level diagram for this atom is shown.

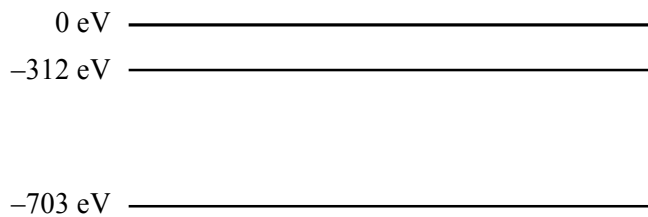

-2810 eV ————— Ground state

State the ionisation energy of this atom.

.....

Calculate the maximum possible wavelength of a photon which, when absorbed, would be able to ionise this atom.

.....  
.....  
.....  
.....

Maximum wavelength = .....

To which part of the electromagnetic spectrum does this photon belong?

.....

(5)

Calculate the de Broglie wavelength of a muon travelling at 11% of the speed of light.

.....  
.....  
.....  
.....

Wavelength = .....

(3)

(Total 8 marks)

11. Ultraviolet light of wavelength 12.2 nm is shone on to a metal surface. The work function of the metal is 6.20 eV.

Calculate the maximum kinetic energy of the emitted photoelectrons.

.....  
.....  
.....  
.....

Kinetic energy = .....

Show that the maximum speed of these photoelectrons is approximately  $6 \times 10^6 \text{ ms}^{-1}$ .

.....  
.....  
.....

(5)

Calculate the de Broglie wavelength of photoelectrons with this speed.

.....  
.....  
.....

Wavelength = .....

Explain why these photoelectrons would be suitable for studying the crystal structure of a molecular compound.

.....  
.....  
.....  
.....

(4)  
(Total 9 marks)

12. The diagram shows some of the energy levels for atomic hydrogen.

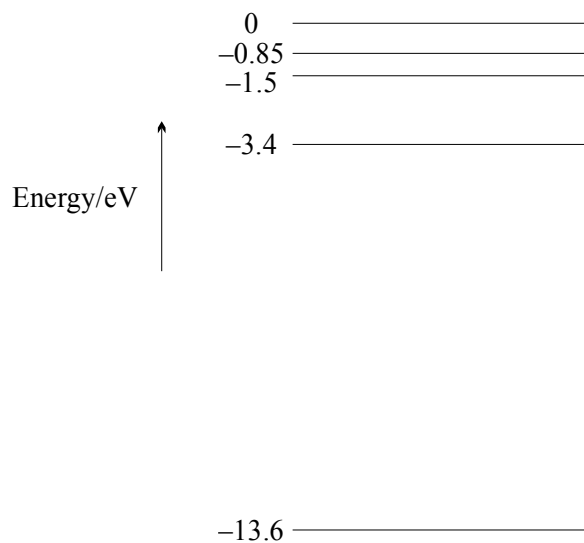

Calculate the ionisation energy in joules for an electron in the  $-13.6$  eV energy level.

.....  
.....

Ionisation energy = .....

(1)

Which change in energy levels will give rise to a blue line ( $\lambda = 490 \text{ nm}$ ) in the hydrogen spectrum?

.....

.....

.....

.....

.....

.....

(4)

Show this change in energy levels on the diagram.

(1)

The spectrum of white light that has been passed through hot hydrogen gas is observed in the laboratory. The continuous spectrum is seen to have a few dark lines across it. One of these dark lines occurs in the blue region of the spectrum at a wavelength of 490 nm.

Explain the origin of this dark line.

.....

.....

.....

.....

(3)

The spectrum of a distant star is observed. It too shows the same pattern of dark lines, but all at longer wavelengths. The line measured at 490 nm in the laboratory occurs at 550 nm in the star's spectrum. What can be deduced about the star?

.....

.....

.....

.....

(3)

(Total 12 marks)

13. A deflated balloon has three points, A, B and C, drawn on its surface. Draw the appearance of the balloon when it is
- (i) partially inflated,
  - (ii) fully inflated.



(2)

The expanding balloon can be used to illustrate *Hubble's law*. Explain how the expanding balloon can be used to illustrate Hubble's law. You may be awarded a mark for the clarity of your answer.

.....

.....

.....

.....

.....

.....

(5)  
(Total 7 marks)

14. The Doppler shift may be used in the study of distant galaxies. Explain what is meant by a Doppler shift and how it is used to deduce the motion of distant galaxies. You may be awarded a mark for the clarity of your answer.

.....

.....

.....

.....

.....

.....

.....

.....

.....

.....

(5)

The graph shows the variation of the size  $S$  of an open universe against time  $t$ .

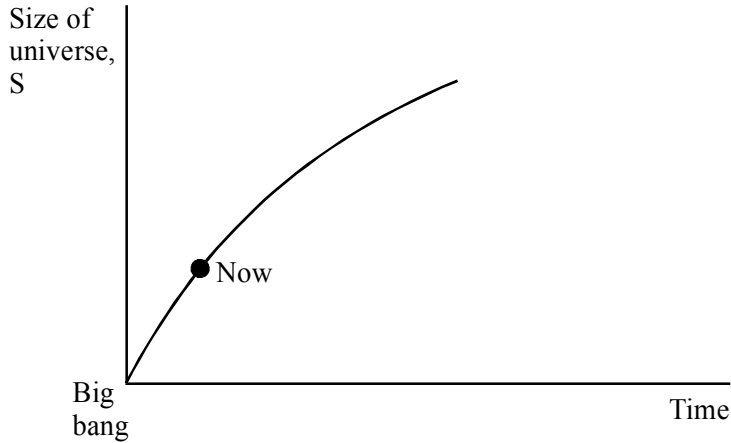

On the same axes, sketch a second graph showing how  $S$  varies with  $t$  for a closed universe.

(1)

It can be shown that the Universe is closed if its density exceeds a critical value  $\rho$ . This is determined from the Hubble constant  $H$  using

$$\rho = kH^2$$

where  $k$  is a known constant.

Outline the experimental difficulties in determining  $\rho$  accurately.

.....  
.....  
.....  
.....  
.....  
.....

(3)  
(Total 9 marks)

15. Calcium has a line spectrum, which includes the spectral line at a wavelength of 393 nm.  
Calculate the frequency of this line.

.....  
.....

Frequency = .....

To which region of the electromagnetic spectrum does this line belong?

.....

(3)

What is a line spectrum?

.....  
.....

(1)

In cosmology, this calcium line may be used to determine the speed of recession of a distant galaxy.

A galactic cluster in Ursa Major has a recessional velocity of  $1.43 \times 10^7 \text{ m s}^{-1}$ .  
Calculate the wavelength of this calcium line as observed from Earth.

.....  
.....  
.....  
.....  
.....

Wavelength = .....

(3)

Given that this galactic cluster is  $1.0 \times 10^9$  light years distant, calculate a value for the Hubble

constant in  $s^{-1}$ .

.....  
.....  
.....  
.....  
.....

Hubble constant = .....  $s^{-1}$

(4)

Another galactic cluster is  $4.0 \times 10^9$  light years away from us. Suggest a value for the recessional velocity of this cluster.

.....  
.....

Velocity = .....

(1)

(Total 12 marks)

16. The following is a simplified energy level diagram for atomic hydrogen.

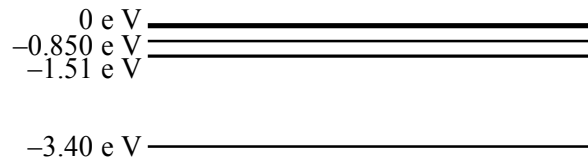

-13.6 eV ————— Ground state

State the ionisation energy of atomic hydrogen.

.....  
.....



Account for the labelling of the energy levels with negative numbers.

.....  
.....  
.....  
.....  
.....

**(3)**

Calculate the wavelength of the photon emitted when an electron moves from the  $-1.51$  eV energy level to the  $-3.40$  eV energy level.

.....  
.....  
.....  
.....

Wavelength = .....

**(3)**

Describe how you would produce a line spectrum of atomic hydrogen in a laboratory.

.....  
.....  
.....  
.....

**(2)**

Sketch what you would expect to see.

**(1)**

**(Total 9 marks)**